

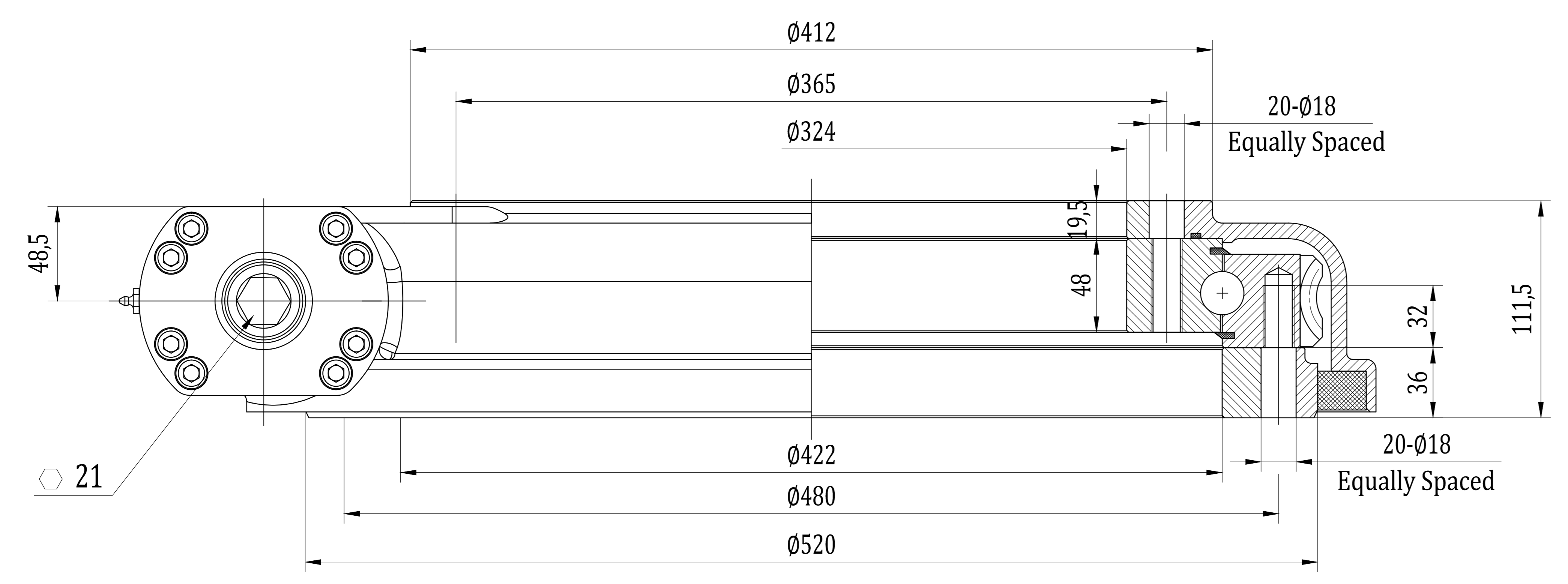

Slewing Drive Performance Parameters		
Rated Output Speed (max)	<3rpm	
Output Torque (max)	20.4 kN.m	15x10 ³ lbf.ft
Tilting Moment	135.6 kN.m	100x10 ³ lbf.ft
Holding Torque	72.3 kN.m	53.3x10 ³ lbf.ft
Static Axial Load Rating	970 kN	218.3x10 ³ lbf
Static Radial Load Rating	390 kN	87.8x10 ³ lbf
Gear Ratio	102:1	
Precision	≤0.15°	

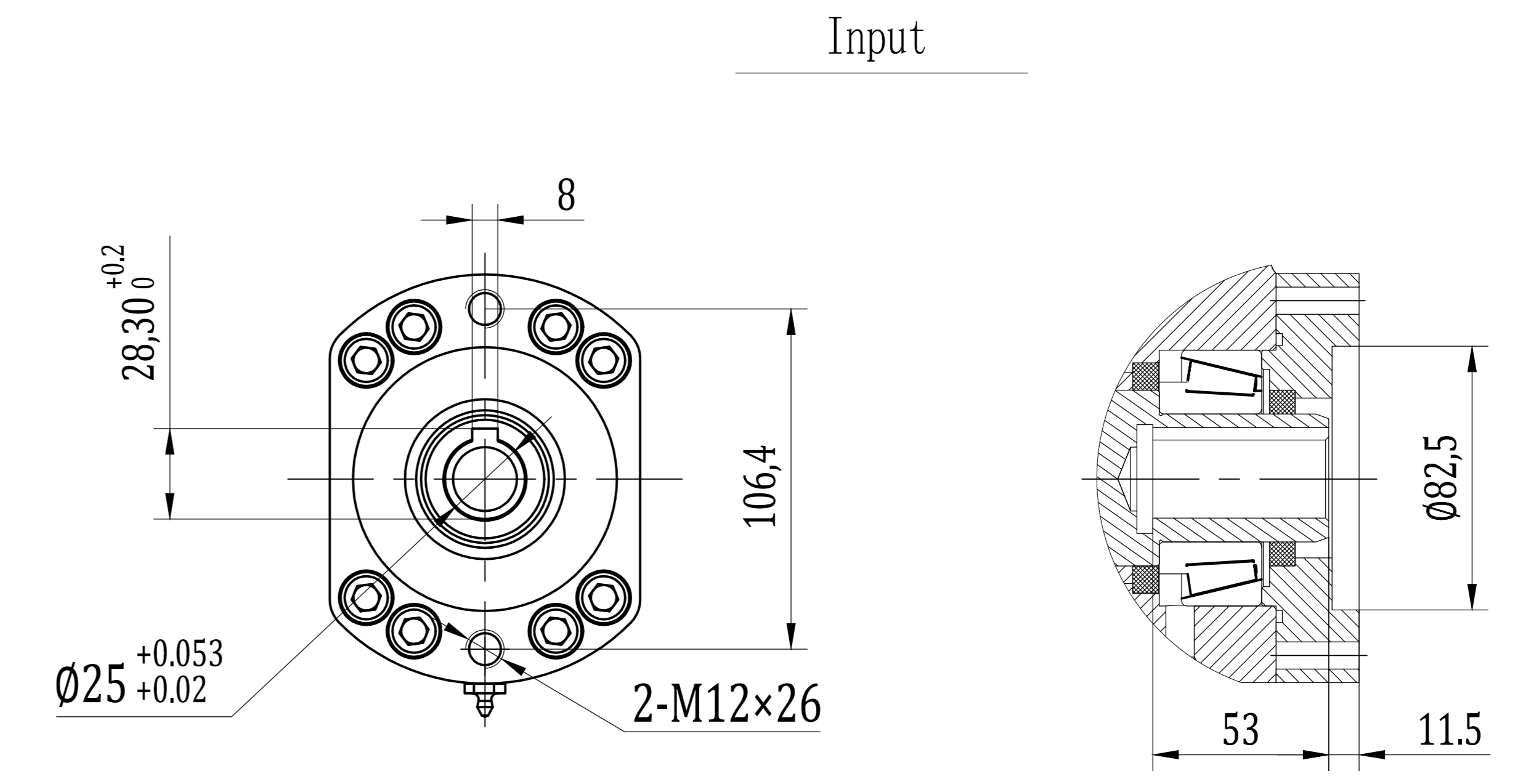
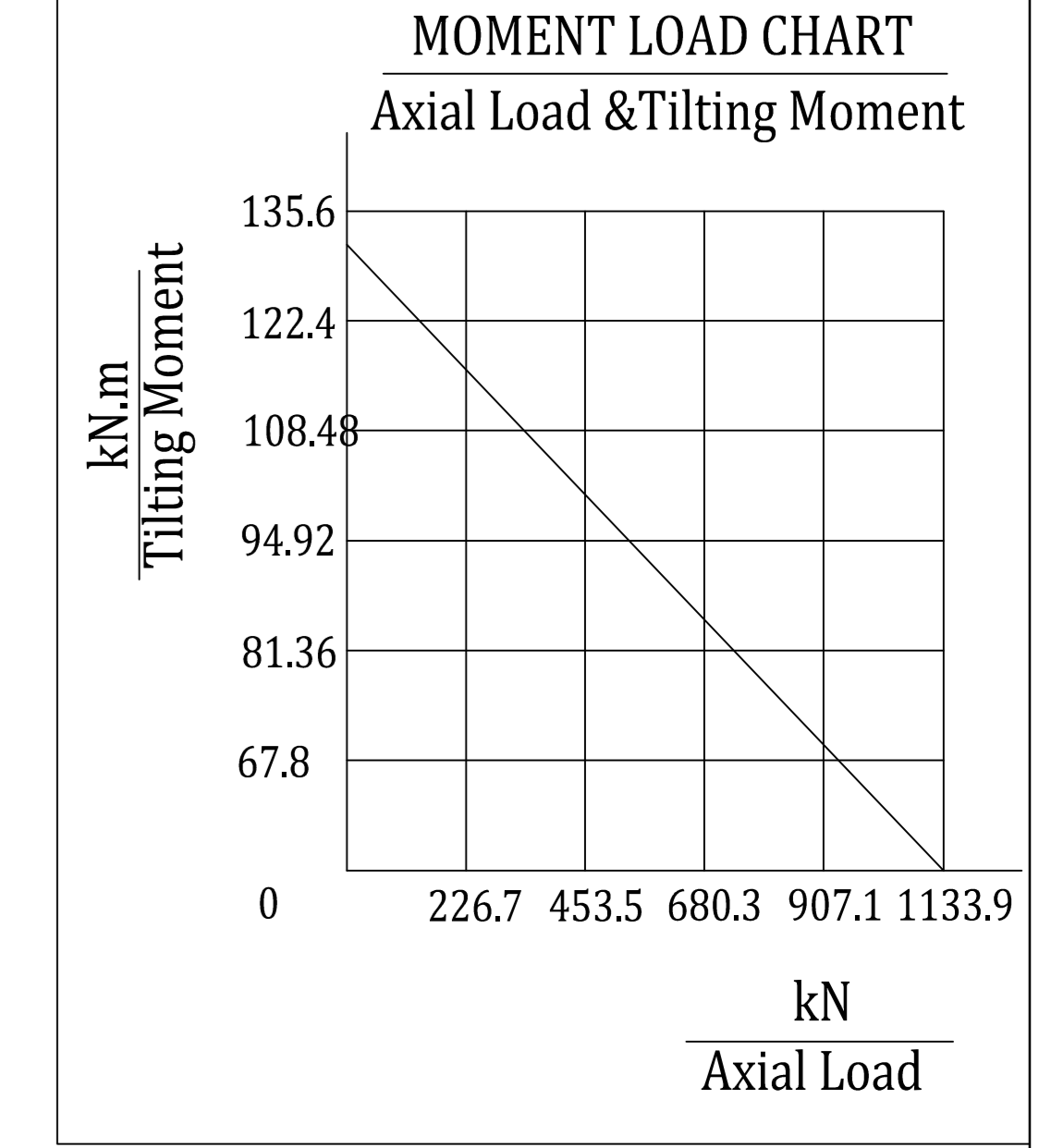

REV	DATE	REVISER	REVISER				
DESIGNED BY	2019/8/1	Li Ming	 www.coresundrive.com Coresun Drive Equipment Changzhou Co., Ltd.				
CHECKED BY	2019/8/1	Rui Wang					
APPROVED BY	2019/8/1	Shane Zhang					
ALL PROPRIETARY RIGHTS IN THE SUBJECT MATTER HERE OF ARE RESERVED, AND NO PERMISSION IS GRANTED OR TO DISCLOSE REPRODUCE THIS PRINT IN WHOLE OR IN PART, ANY OF THE INFORMATION TO OTHERS.			WEIGHT	SCALE	<h2>Slewing Drive</h2>		
SYMBOLS ISO			98 kg	1 : 4			
			SIZE	A3			
			SHEET	1 / 1	WH17-102-25RH <table border="1" style="float: right;"> <tr> <td>REV</td> <td>A</td> </tr> </table>	REV	A
REV	A						